

Bulk Metal® Foil Technology Molded Resistor Networks

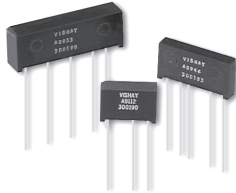

Product may not be to scale

Unitized Resistor Networks are comprised of Vishay S102C elements combined and molded into single units. This method of making networks yields some important advantages that should be considered where space is not a limitation and maximizing performance is important. To begin with, the leads that emerge from the package go directly to the resistance element (or an internal PC board), so the possibility of thermal EMFs is very low. Next, the value range of the elements is large (1 Ω to 150 k Ω in a single foil element) and they can be combined for even higher values. Finally, these elements possess all the good features of discrete Bulk Metal® Foil resistors, plus the ability to be further sorted for TCR track and absolute match before encapsulation. These networks make excellent voltage dividers, bridges, and attenuators where performance and stability are important.

APPLICATIONS

- Differential amplifiers
- Gain defining resistors in digital voltmeters
- Ratio arms in bridge circuits
- Fuel metering systems
- Heads up displays
- Fire control systems
- Spacecraft instrumentation
- Naval weapons systems
- Binary Coded Decimal Ladder Networks
- Binary Ladders (A-D, D-A conversion, current and voltage summing)
- Ratio and Ratio-matching Networks
- Bridge Networks
- Synchro Input and Summing Networks
- Resolver Networks
- Linear and Linear-summing Networks
- Decoder Networks
- Quadrature Bridge Networks
- Resistive Summing Networks

FEATURES

- Resistance range each resistor: 1 Ω to 150 k Ω
- TCR Tracking: to ± 0.5 ppm/ $^{\circ}$ C
- Nominal TCR each resistor: See Figures 1 and 2 in data sheet "7 Technical Reasons to Specify Bulk Metal® Foil Resistor Networks."
- Nominal tolerance ratio matching between resistors: from ± 0.005 to ± 1 %
- Absolute tolerance each resistor: ± 1.0 %, ± 0.5 %, ± 0.25 %, 0.1 %, ± 0.05 %, ± 0.02 %, ± 0.01 %, ± 0.005 %
- Power rating: 0.25 watts per resistor

TABLE 1 - TYPICAL¹⁾ PERFORMANCE CHARACTERISTICS

Resistance Temp Characteristic (TCR) TCR Tracking To Reference Element		± 2 ppm/ $^{\circ}$ C nominal 0.1 ppm/ $^{\circ}$ C to 4 ppm/ $^{\circ}$ C ⁴⁾	
Max Ambient Temp at Rated Wattage		+ 125 $^{\circ}$ C	
Max Ambient Temp at Zero Power		+ 175 $^{\circ}$ C	
Thermal Shock	ΔR ²⁾	0.002 %	
	Δ Ratio ³⁾	0.002 %	
Low Temperature Operation	ΔR	0.005 %	
	Δ Ratio	0.002 %	
Short Time Overload	ΔR	0.002 %	
	Δ Ratio	0.002 %	
Terminal Strength	ΔR	0.001 %	
	Δ Ratio	0.001 %	
Resistance to Soldering Heat	ΔR	0.002 %	
	Δ Ratio	0.001 %	
Moisture Resistance	ΔR	0.003 %	
	Δ Ratio	0.003 %	
Shock	ΔR	0.001 %	
	Δ Ratio	0.001 %	
Vibration, High Frequency	ΔR	0.001 %	
	Δ Ratio	0.001 %	
Life	0.3 W at + 125 $^{\circ}$ C	ΔR 0.01 %	
	0.02 W at + 60 $^{\circ}$ C	ΔR 0.003 %	
	0.05 W at + 25 $^{\circ}$ C	ΔR	0.001 %
		Δ Ratio	0.002 %
High Temperature Exposure	ΔR	0.01 %	
	Δ Ratio	0.01 %	
Low Temperature Storage	ΔR	0.002 %	
	Δ Ratio	0.002 %	
Insulation Resistance		> 500 000 M Ω	
Dielectric Withstanding Voltage		No Change	
Voltage Coefficient ⁵⁾	ΔR	< 0.1 ppm/V ⁵⁾	
	Δ Ratio	< 0.1 ppm/V ⁵⁾	
Noise	N/A	- 40 dB (non-measurable)	
Inductance	N/A	0.08 μ H	
Capacitance	N/A	0.5 pf	
Rise Time	N/A	1 ns at 1 k Ω	
Thermal EMF lead to lead	N/A	0.04 μ V/ $^{\circ}$ C	
Thermal EMF air circulation	N/A	0.02 μ V/ $^{\circ}$ C	
Thermal EMF power	N/A	0.1 μ V for 20 mW	
Shelf Life	ΔR ⁶⁾	25 ppm/year	
	Δ Ratio ⁶⁾	10 ppm/year	

NOTES:

1. Typical is a designer's reference that represents 85 % of production. Most of the DR's shown are maximums. To ensure that all typical values are maximums a "burn-in" is required.
2. ΔR : absolute resistance change.
3. Δ Ratio: change in ratio between resistors within the network package from before to after the specified test
4. Depending on construction and ratio value
5. Measured < 0.1 ppm/V and within the measurement capability of the equipment. Voltage coefficient is "essentially zero"
6. 2 ppm when in hermetically sealed package

FIGURE 1 - VISHAY MODEL 300198 NETWORK

APPLICATION EXAMPLE

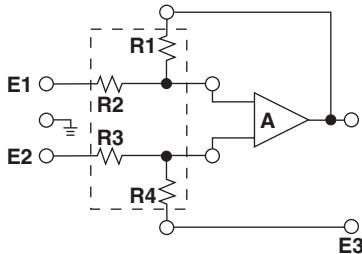

FIGURE 2 - POWER DERATING CURVE

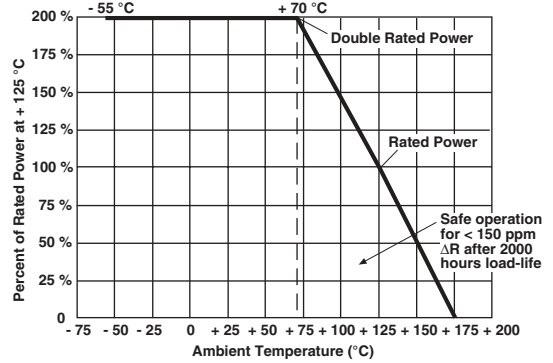
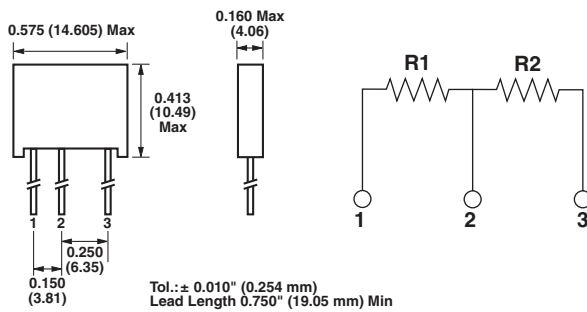
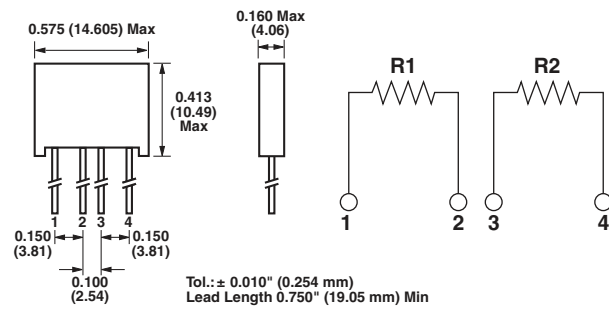

FIGURE 3 - MOLDED 2R, 3R, 4R RESISTOR NETWORK DIMENSIONS AND CIRCUIT DESIGN in inches (millimeters)

MODEL 300190



MODEL 300191



MODEL 300192

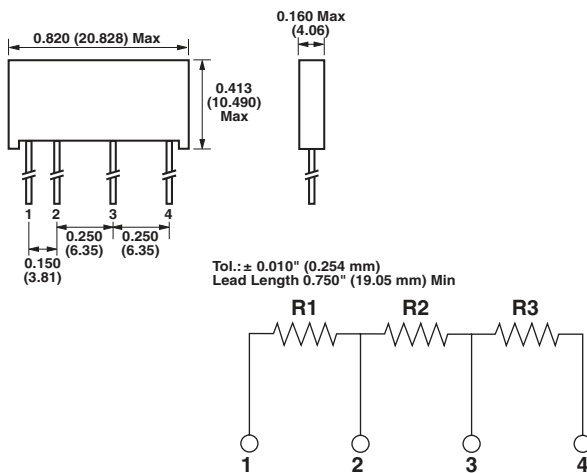

MODEL 300193

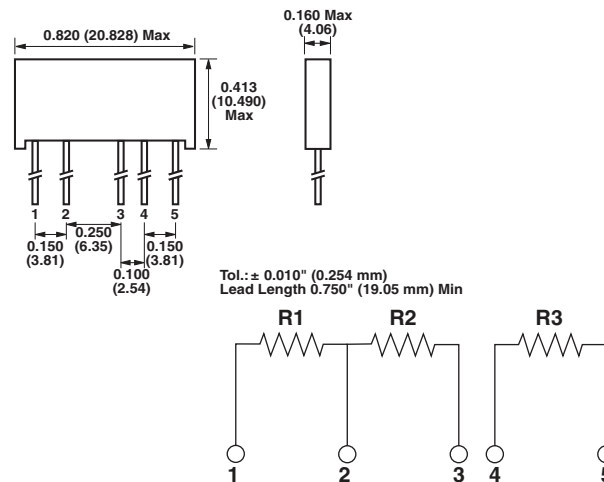
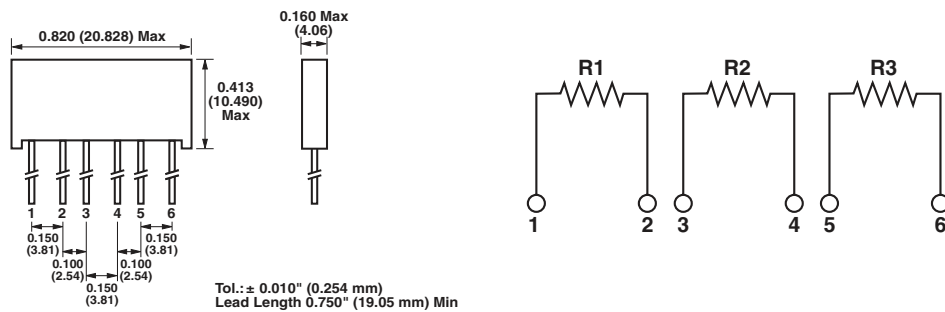
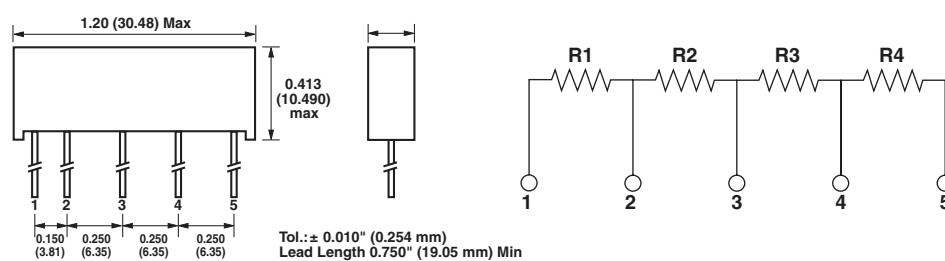

FIGURE 4 - MOLDED 2R, 3R, 4R RESISTOR NETWORK DIMENSIONS AND CIRCUIT DESIGN in inches (millimeters)

MODEL 300194



MODEL 300195



MODEL 300196

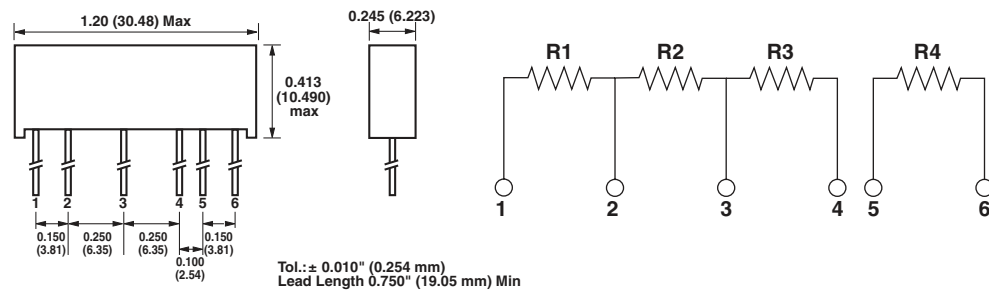

MODEL 300197

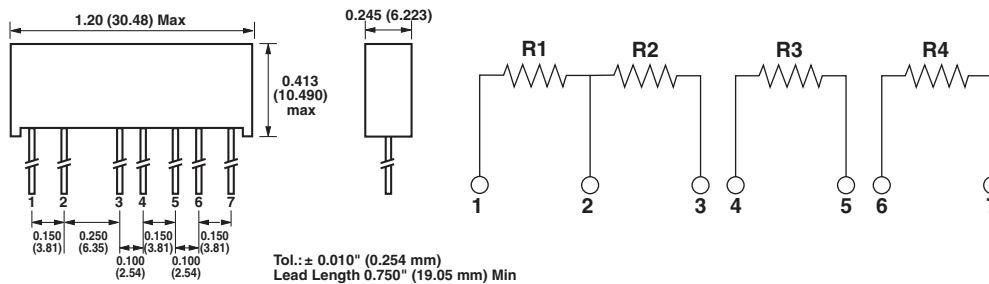

MODEL 300198

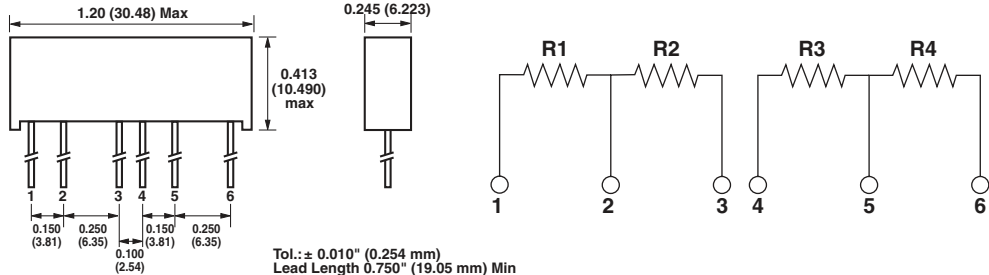
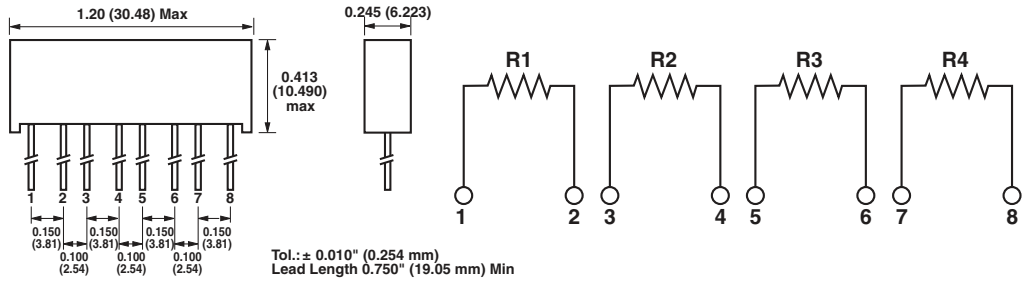
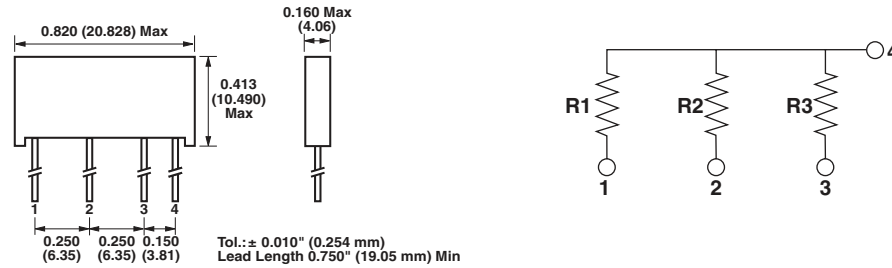

FIGURE 5 - MOLDED 2R, 3R, 4R RESISTOR NETWORK DIMENSIONS AND CIRCUIT DESIGN in inches (millimeters)

MODEL 300199



MODEL 300210



MODEL 300211

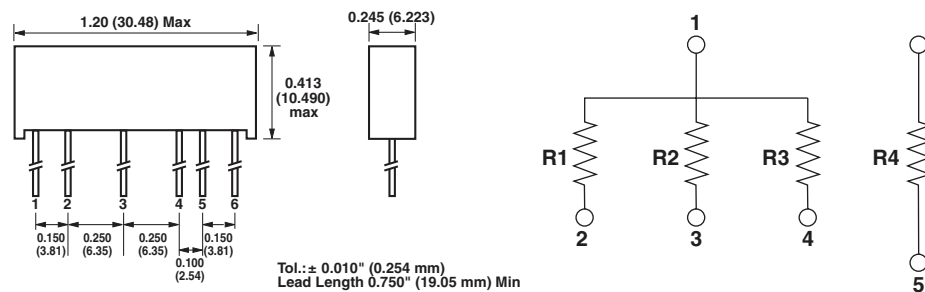

MODEL 300212

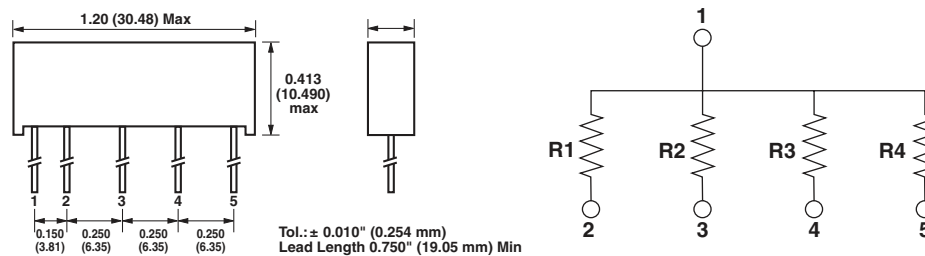

ORDERING INFORMATION - MOLDED 2R, 3R AND 4R RESISTOR NETWORKS

Networks are built to your requirements. Send your schematic and electrical requirements to the Applications Engineering Department. (See data sheet "Network Worksheet") A unique part number will be assigned which defines all aspects of your network.

Disclaimer

All product specifications and data are subject to change without notice.

Vishay Precision Group, Inc., its affiliates, agents, and employees, and all persons acting on its or their behalf (collectively, "Vishay Precision Group"), disclaim any and all liability for any errors, inaccuracies or incompleteness contained herein or in any other disclosure relating to any product.

Vishay Precision Group disclaims any and all liability arising out of the use or application of any product described herein or of any information provided herein to the maximum extent permitted by law. The product specifications do not expand or otherwise modify Vishay Precision Group's terms and conditions of purchase, including but not limited to the warranty expressed therein, which apply to these products.

No license, express or implied, by estoppel or otherwise, to any intellectual property rights is granted by this document or by any conduct of Vishay Precision Group.

The products shown herein are not designed for use in medical, life-saving, or life-sustaining applications unless otherwise expressly indicated. Customers using or selling Vishay Precision Group products not expressly indicated for use in such applications do so entirely at their own risk and agree to fully indemnify Vishay Precision Group for any damages arising or resulting from such use or sale. Please contact authorized Vishay Precision Group personnel to obtain written terms and conditions regarding products designed for such applications.

Product names and markings noted herein may be trademarks of their respective owners.